

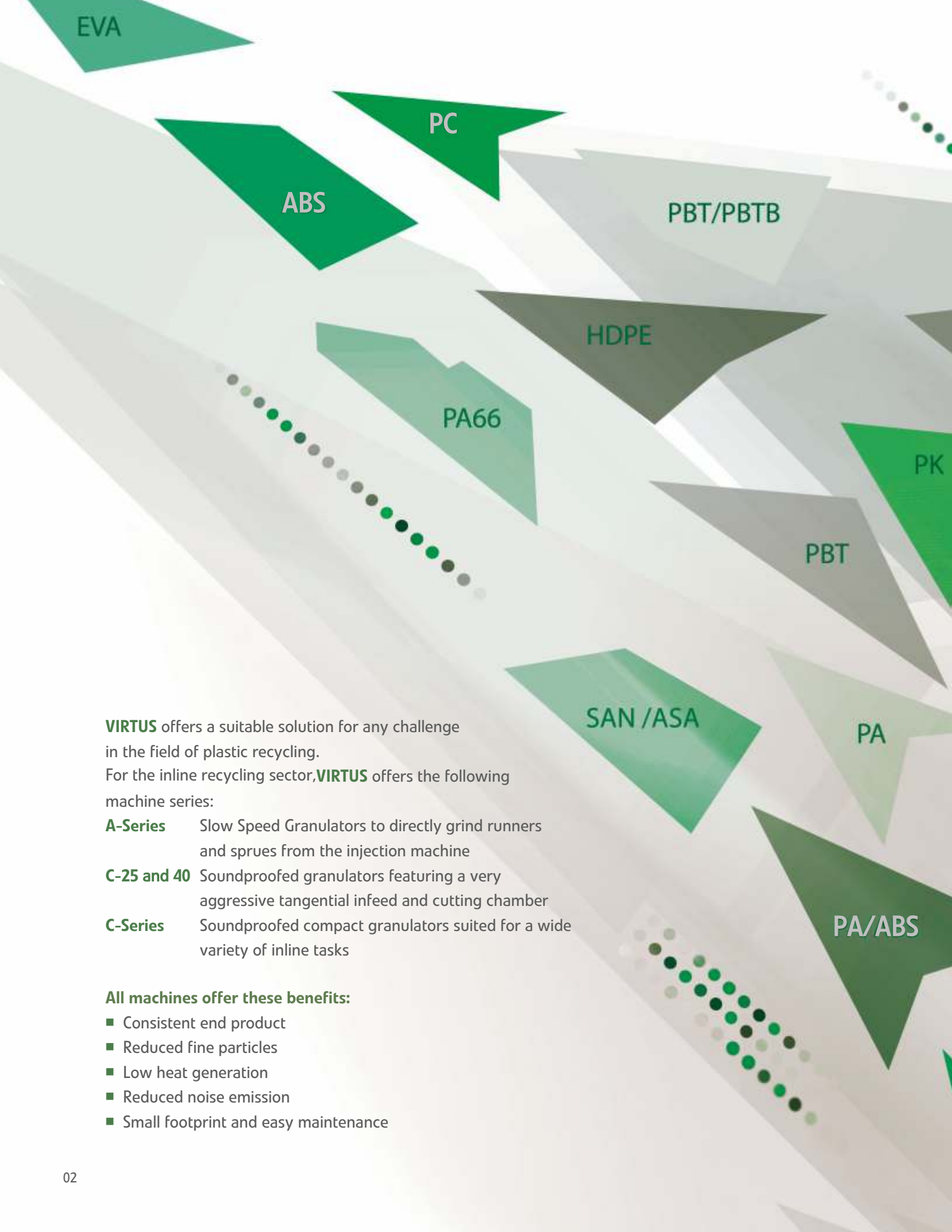

Solutions for Inline Recycling
A and C Series

virtus

The Right Machine for
Today's Recycling Requirements



VIRTUS offers a suitable solution for any challenge in the field of plastic recycling. For the inline recycling sector, **VIRTUS** offers the following machine series:

- A-Series** Slow Speed Granulators to directly grind runners and sprues from the injection machine
- C-25 and 40** Soundproofed granulators featuring a very aggressive tangential infeed and cutting chamber
- C-Series** Soundproofed compact granulators suited for a wide variety of inline tasks

All machines offer these benefits:

- Consistent end product
- Reduced fine particles
- Low heat generation
- Reduced noise emission
- Small footprint and easy maintenance

Take control of your scrap

Granulation and size reduction of plastics, (e.g. scrap from blow and injection molding or extrusion processes) requires a lot of know-how and experience.

VIRTUS has a long history in the design and implementation of size reduction equipment, and offers a product portfolio as wide as the spectrum of materials that need to be processed.

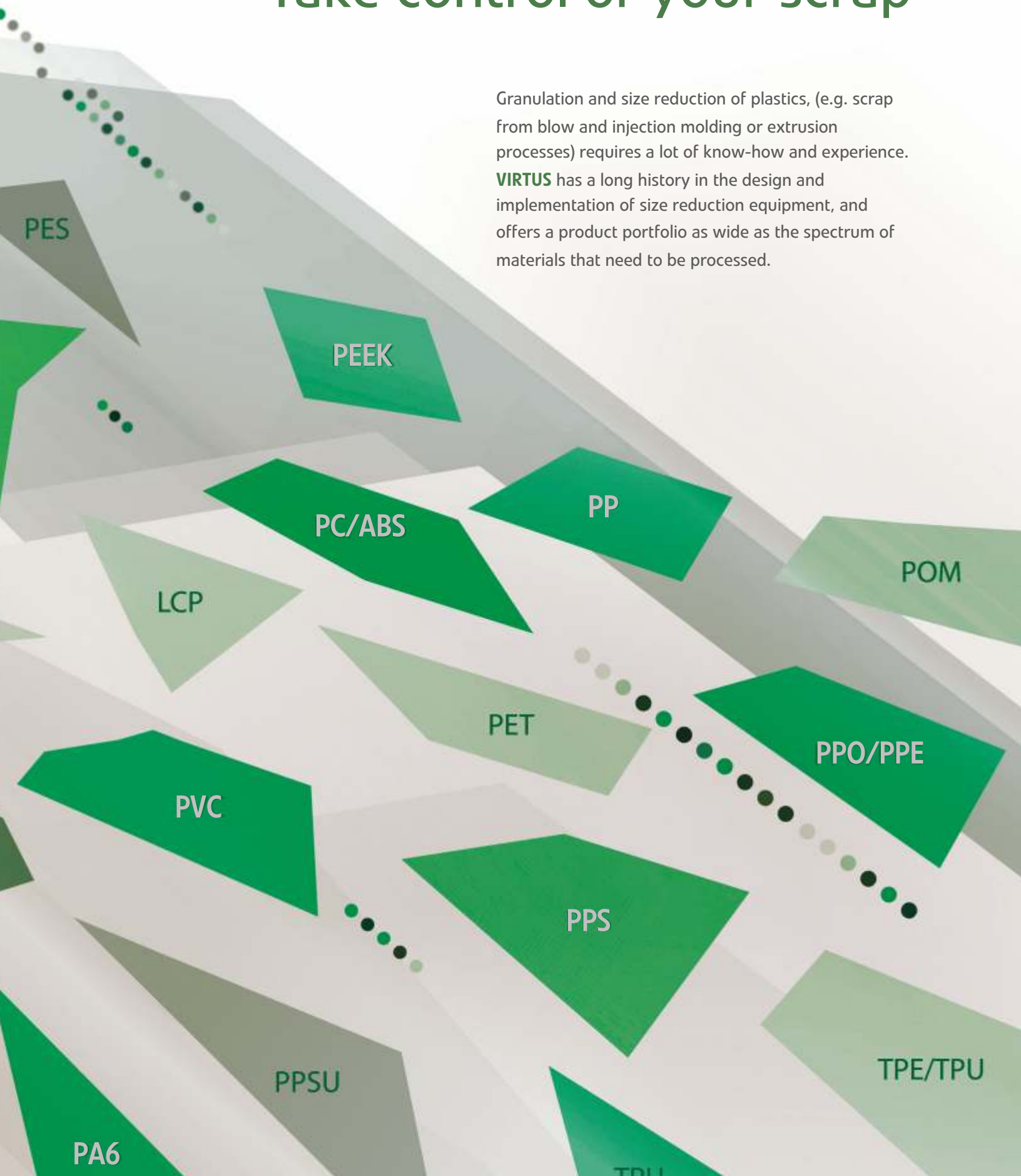

Inline recycling application examples

A Series

A Series slow speed granulator

working next to an injection molding machine, directly grinding runners and rejects.

The regrind is directly reintroduced into the production.

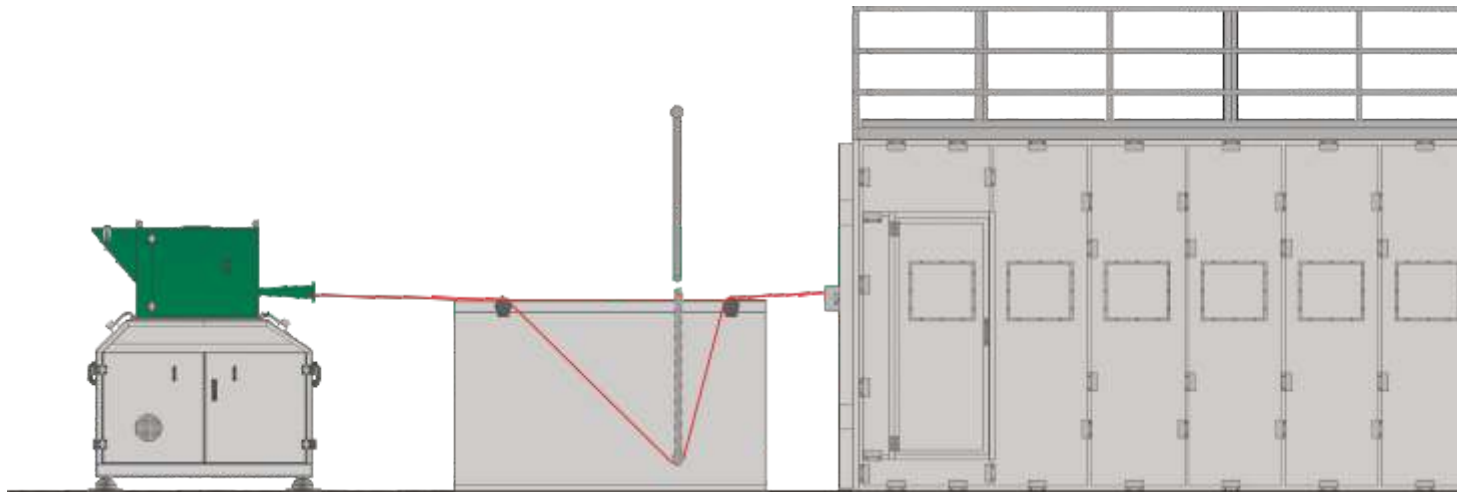
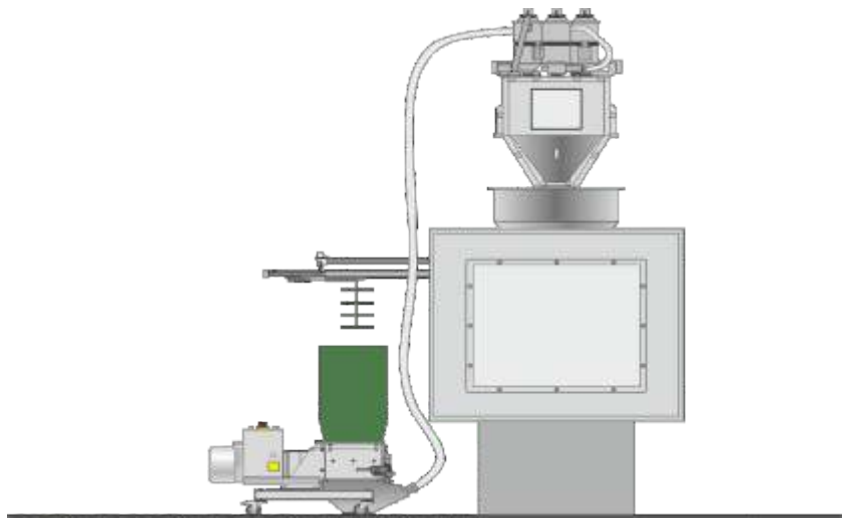

VIRTUS granulators can be integrated into a variety of production operations. Common applications include the processing of rejects and scrap from injection molding of small parts (like caps and closures to TVs or automotive components), as well as flush from blow molding applications.

With an optional roller feeder, the machines can be used for the inline processing of edge trim and skeletal waste in extrusion and thermoforming lines.

Our skilled and experienced team of engineers will help you integrate a **VIRTUS** system into your facility and design a tailored solution.

C 25 and 40

C 25 and 40

in a blow molding application. Tops and tails are fed to the granulator by a conveyor and the resulting material is directly fed back into the extruder.

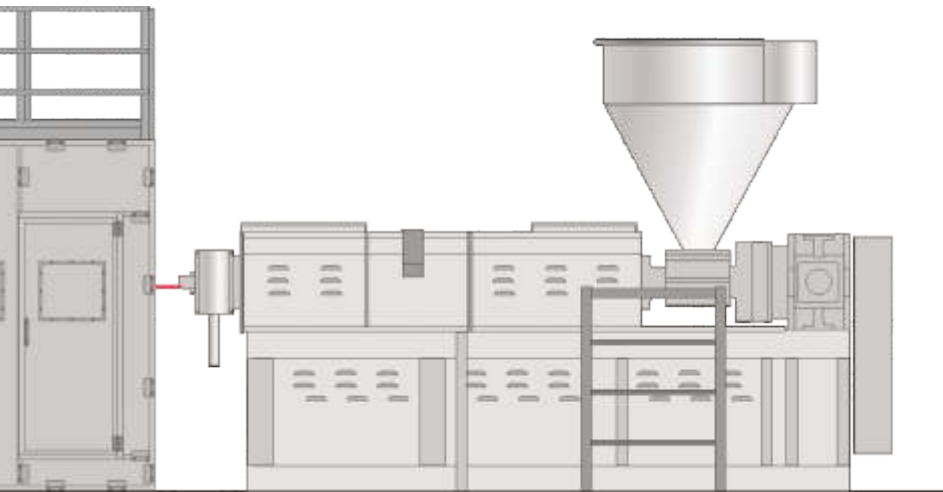
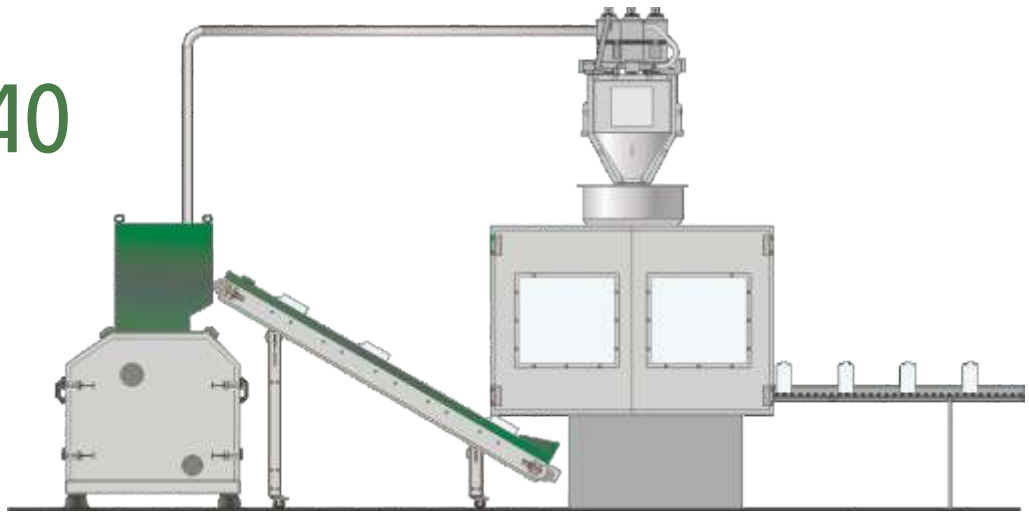

C Series

C Series

grinding skeletal waste in a thermoforming process. The machine is equipped with a dual feed hopper in order to accept reject products.



Advanced engineering – great results

The right machine for today's inline



The **VIRTUS** granulators of the A and C series are designed for the inline recycling of scrap (e.g.- runners, sprues, tops, tails, and reject parts) directly at the production machine. The resulting regrind can either be collected in a central silo or be mixed with virgin material and reused immediately. The compact size and low noise of these machines make them a perfect fit for in-house applications.

recycling requirements



Highlights

- Machines can be integrated into the production line
- Low dust and noise emission
- Simple maintenance and up to date safety design
- Different cutter and rotor designs to fit specific applications tailored to inline applications

VIRTUS range of inline granulators

C 25 and 40 series – aggressive tang

The **VIRTUS** tangential granulators of the C series are available in two rotor diameters, 250 and 400 mm, with widths ranging from 300 to 1000 mm.

While the smaller machines feature an open F rotor, the bigger machines rely on a heavier S rotor.

The rigid design makes them dependable units and includes advanced standard features such as replaceable wear plates.



Highlights

- Compact design
- Soundproofed chamber and hopper
- Aggressive infeed and curved backwall
- Large screen area
- Knives are adjusted outside the machine

ential infeed



C-40 – opened

Small footprint – great results

The **VIRTUS C** compact/soundproof granulators are designed with a complete soundproof enclosure resulting in an extremely quiet operation. Different rotor designs are available in widths ranging from 300 to 1400 mm with a diameter ranging from 300 to 700 mm.

The completely welded cutting chamber, in conjunction with the V rotor design, ensures dependability during operation and universal application use.

While it delivers excellent soundproofing capabilities, it still offers easy and quick access to the cutting chamber during rotor and stator knife changes, servicing, or screen changes.

Highlights

- Sturdy compact design
- Different rotor types available
- Soundproofed housing
- Knives are adjusted outside of the machine
- Integrated controls



series – the soundproofed all-rounder



C Series – with optional feeding conveyer

Efficient cut – great result

A series – dependable low speed pe

The beside the press granulators of the **VIRTUS** A series run at a low speed to ensure low noise operation and low dust regrind. The specially designed rotor knives can be sharpened numerous times, and due to their unique design, do not need to be adjusted. The granulators are fed via a sound absorbing hopper which can be tailored to fit your specific needs. All A series machines offer connections for vacuum systems in order to directly reintroduce the regrind into your production process.

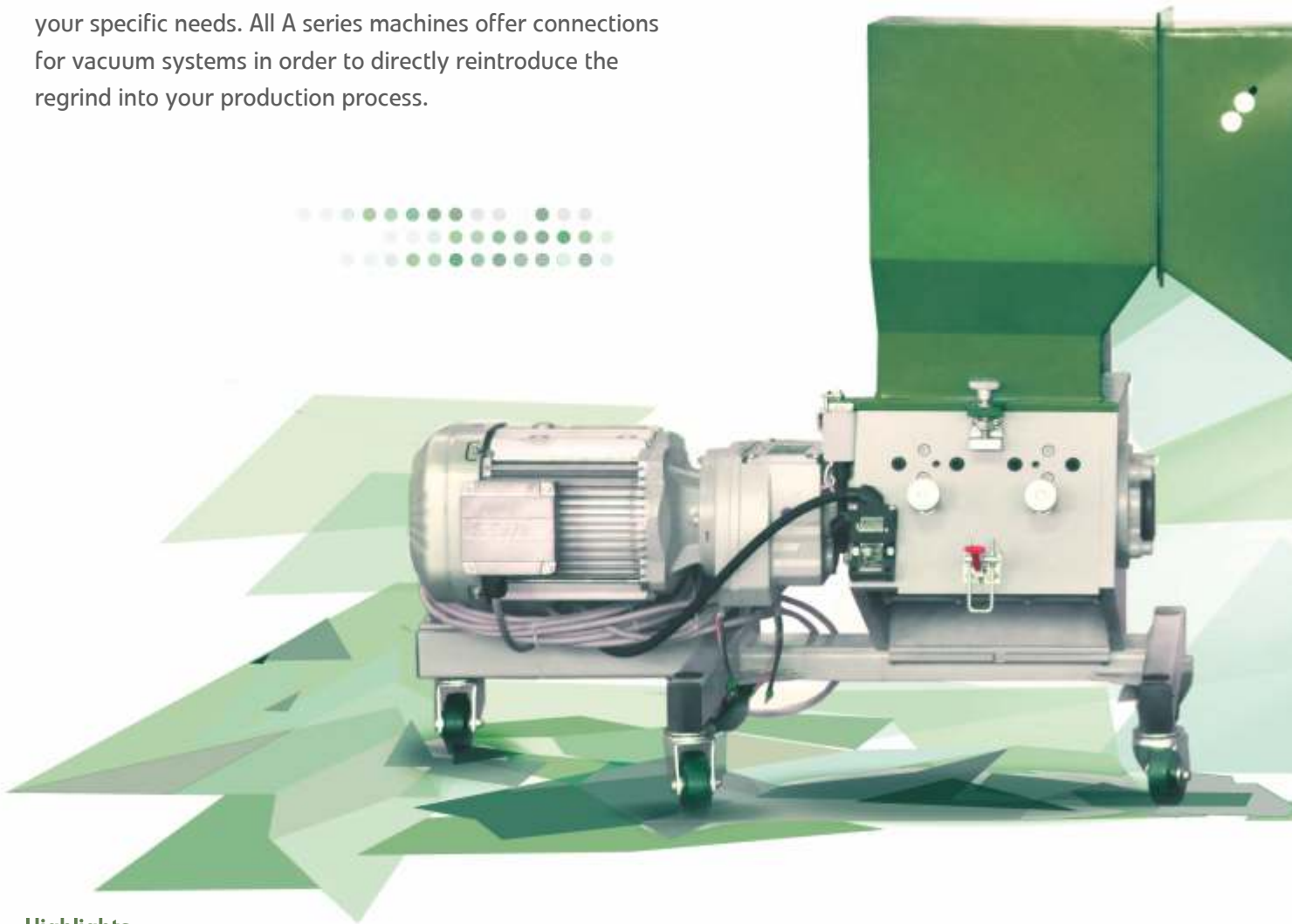

Highlights

- Direct drive
- Specially designed rotor knives do not need to be adjusted in the machine
- Easy tool-less access to the machine for maintenance and cleaning
- Frame and hopper can be tailored to fit your needs

Performance

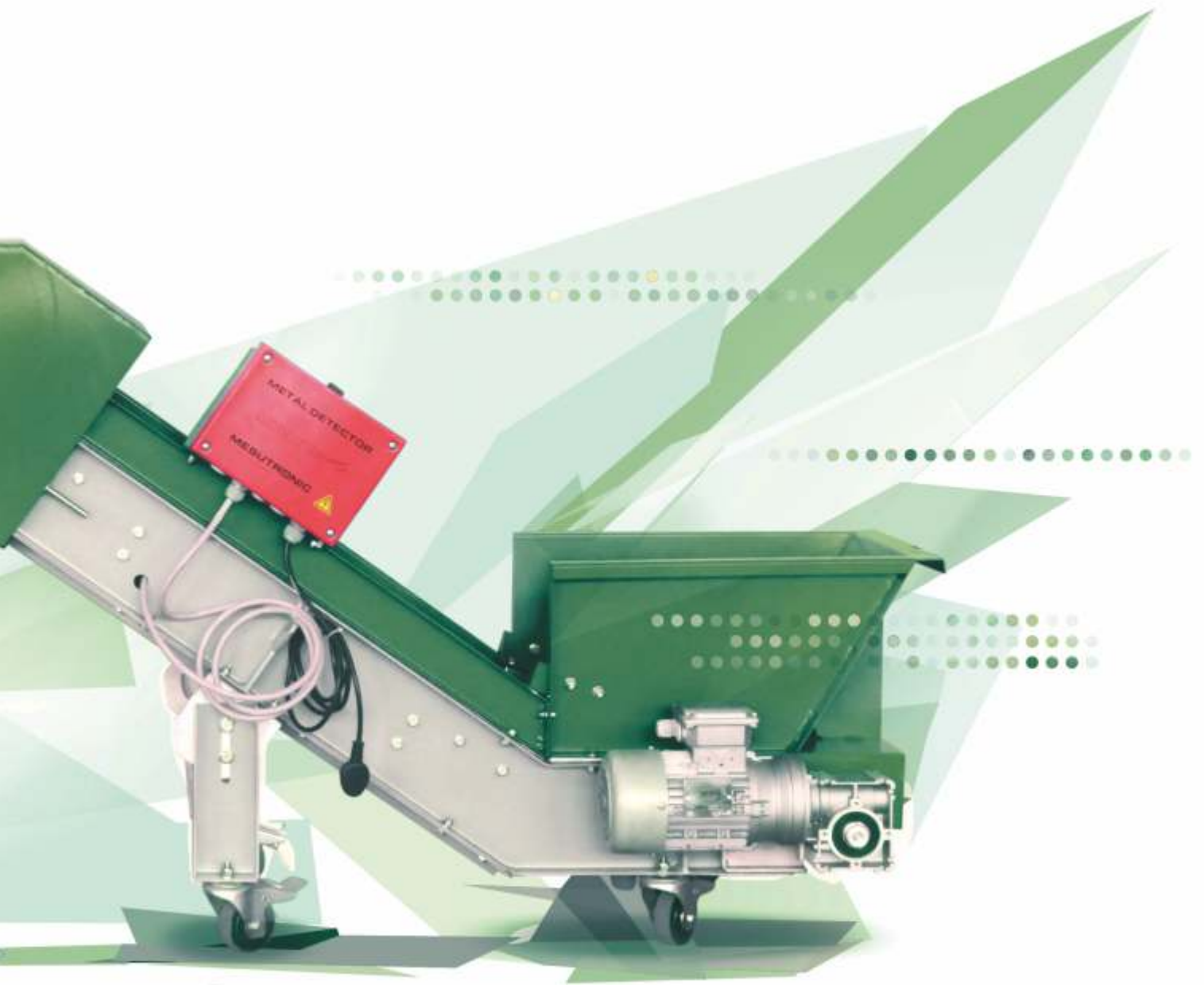

A Series – with optional conveyor belt and integrated metal detector

Low speed – great results

Technical details – well thought out



A Series:

The curvature of the specially profiled rotor knives ensures a constant cutting radius after re-sharpening, thus maintaining the original cutting gap. Awkward knife adjustment is no longer necessary.



A Series:

The Quick Snap System allows the lower front plate section to be easily removed for granulator cleaning. The lower front plate section is held in position by two sturdy lever clamps.



A Series:

Staggered rotor blades create an individual blade cut thus increasing the cutting torque. All of the machines in this series are therefore suitable for grinding more solid materials and thicker walled sprues.



C Series:

The granulators are available with different rotor options to fit different applications. All rotors feature the V-cut technology creating a high quality regrind.

A and C Series:

All machines are designed according to the latest mechanical and electrical safety requirements.



Advanced engineering – great results

and efficient



C 25 and 40 Series:

The curved back wall of the cutting chamber ensures aggressive ingestion while also avoiding blockages.



C Series:

Replaceable wear plates in the cutting chamber ensure a long service life of the granulator even with difficult materials.



C Series:

In order to keep the machines as compact as possible, the motor and opening system are integrated into the sound dampening enclosure of the machine.



C Series:

The user friendly design of the granulators allows quick and easy access to the cutting chamber for maintenance and cleaning.



Technical specifications – overview

Applies to all models: screen size is >5 mm or > 6 mm and each machine has 2 rows of stator blades.
The model name is composed of the rotor diameter and rotor width (A/B)

- A** = Rotor diameter in mm
- B** = Rotor width in mm
- C** = Drive capacity in kW
- D** = Rotor knives in pcs

ExF = Feed opening in mm x mm

- All Dimension are in mm
- G** = length
- H** = height
- I** = width

A Series:

A/B	180/120	180/180	180/300	180/430	200/180	200/270	200/360	200/500	300/400	300/600	300/800
C	2,2	3	4	4	3	3	4	4	7,5	11	18,5
D	12	18	30	45	12	18	24	33	33	48	66
ExF	345x345	345x345	345x345	430x290	230x245	310x245	470x245	545x245	405x400	600x400	830x400
G	835	890	1095	1240	985	1110	1255	1415	1125	1125	1135
H	1070	1070	1070	1360	1260	1290	1335	1355	1735	1735	1740
I	455	455	455	615	510	510	510	510	1035	1230	1635

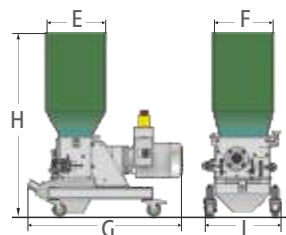

C 25&40 Series:

A/B	250/300	250/450	250/600	400/600	400/1000
C	7,5	11	18,5	22	30
D	3x1	3x1	3x2	3x2	3x2
ExF	300x370	450x370	600x370	590x490	990x490
G	1350	1600	1750	1550	1950
H	1880	1880	1880	2180	2180
I	1220	1220	1220	1460	1460

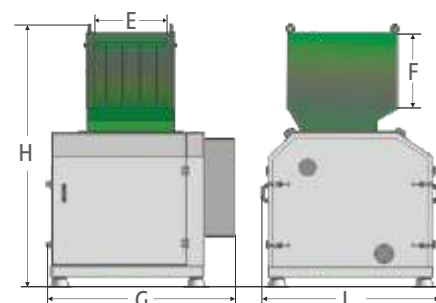



C Series:

A/B	300/300	300/600	300/1000	300/1400	500/500	500/700	500/1000	500/1400	700/700	700/1000	700/1400
C	7,5	11	18,5	22	30	37	45	45	45	55	55
D	3	3	3	3	3 or 5	3 or 5	3 or 5	3 or 5	5 or 7	5 or 7	5 or 7
ExF	300x420	590x420	990x420	1400x420	500x600	700x600	990x540	1400x540	700x740	990x740	1400x740
G	1550	1550	1550	1660	2010	2010	2410	2410	2560	2560	2560
H	1990	1990	1990	2065	2395	2395	2565	2580	2880	2880	2980
I	1360	1680	1950	2220	1380	1580	1880	2210	1560	1850	2210

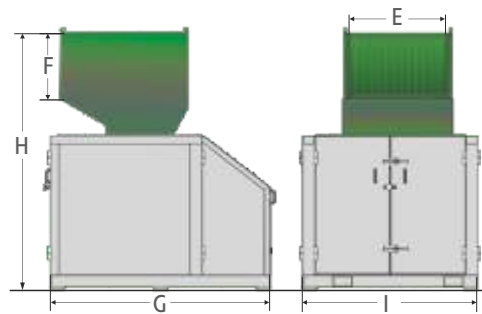

Wide range – great results

The product range – the right solution



PM-Series - Pulverizer

E-Series - Economical granulators

H-Series - Heavy duty granulators

With more than 75 years of experience, **VIRTUS** is one of the leading manufacturers of high quality size reduction machinery. From the small A slow speed granulators to the versatile H heavy duty granulators, our product lines also include small, compact granulators with integrated blower and soundproofing.

Specialized machines are available like the pipe and profile granulators and the **VIRTUS** PM disc pulverizer systems for fine grinding applications. Adding a complete line of shredders, starting with light shredders for wood applications, up to large heavy duty shredders, **VIRTUS** recycling machines range in drive power from 2.2 kW up to 200 kW, and cover the whole spectrum of plastic size reduction applications.

on for any application



X-T-Series - Heavy duty shredders

VIRTUS

The Right Machine for
Today's Recycling Requirements



The Right Machine for Today's Recycling Requirements



VIRTUS Equipment
311 Era Drive • Northbrook, Illinois 60062

Phone: 847-291-1800
sales@virtus-equipment.com

virtus-equipment.com