

PM

High Speed Precision Pulverizer

- Simple adjustment of cutting gap
- Choice of discs or segments
- Low drive power - High throughput
- Innovative efficient design
- Wide range of accessories
- Easy temperature control

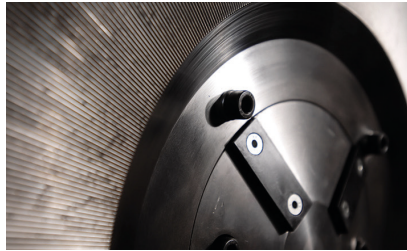

The Virtus PM Pulverizers can be equipped with either one piece or segmented grinding discs. Both are made from high quality tool steel and can be treated to withstand wear longer.

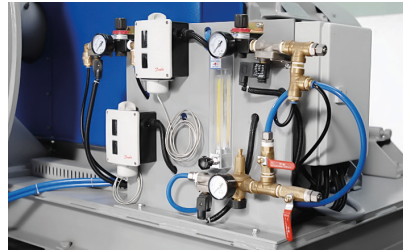

The material temperature is monitored in the process, and an automated cooling system will ensure the temperature is kept at a defined level.

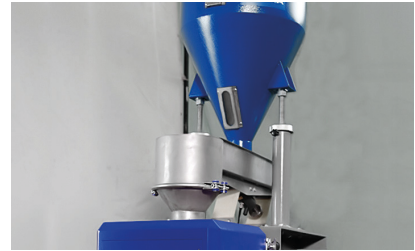

The material is fed into the Pulverizer by a vibrating dosing channel, and the feeding rate is automatically adjusted based on the motor's amperage and material temperature.

General Description

The disc pulverizers of the PM series are available with disc diameter from 300 to 800 mm. These pulverizers are high speed, precision grinders for the processing of medium hard, impact resistant and friable materials. The material to be pulverized is introduced through the center of a vertically fixed grinding disc which is mounted concentrically with an identical high speed rotating disc. Centrifugal force carries the material through the grinding area and the resulting powder is collected with a blower and cyclone system. Depending on the application, the machines can be equipped with one piece grinding discs or grinding segments.

Applications

One of the main fields of use for the Virtus PM Pulverizers is the pulverization of PVC regrind in pipe and profile recycling. Working in line with a shredder and granulator creates a balanced and efficient system to handle in house production waste. Another application is the grinding of PE for Rotomolding applications. Here the PM Pulverizer is used in the production process to create the powder needed in the process. In this process, a screening machine is necessary to ensure the right output size, distribution, and flow properties of the ground material.

PM

High Speed Precision Pulverizer

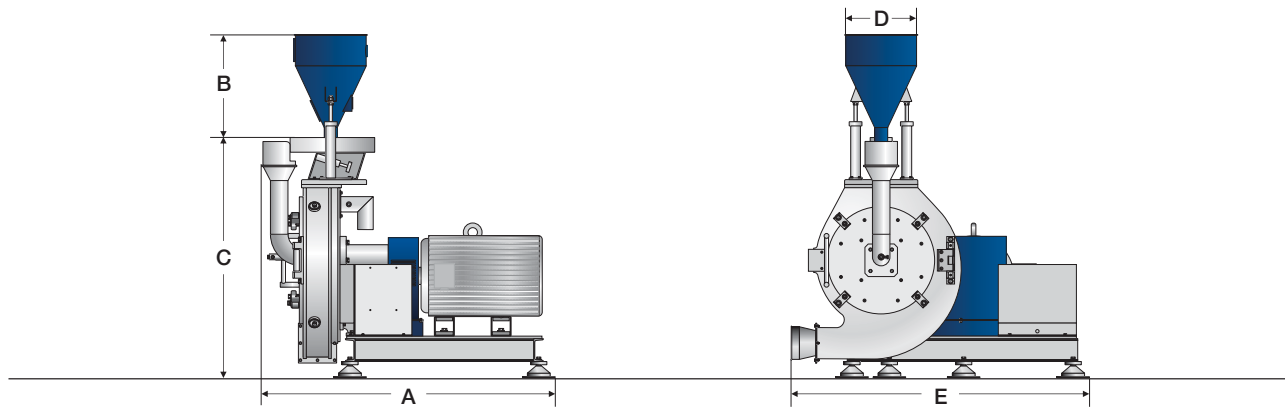

Technical Specifications and Dimensions

Model	300	500	800
Discs diameter (mm)	300	500	800
Drive capacity (kW)	22	55	90
Weight approx (kg)	900	1800	2500
Throughput approx (kg/h)	50-500	100-1000	200-1500
A (mm)	1365	1800	2085
B (mm)	640	640	640
C (mm)	1190	1470	1800
D (mm)	435	435	435
E (mm)	1515	1680	1840

Virtus Equipment

9120 Centerlinks Commerce Dr., Unit 4
Fort Myers, FL 33912

239-219-1800
Sales@Virtus-Equipment.com

virtus-equipment.com

Virtus
Equipment

The Right Machine for Today's
Recycling Requirements