

X Series

Heavy duty shredders

- Low speed, high torque gear drive
- Powerful two speed hydraulic swing type ram
- Heavy Duty design
- High throughput rates
- Suitable for very large and heavy parts
- Large diameter rotor (750 mm)



The shredders use concave square knives, producing high quality output. The cutters can be turned after a side is worn out.



All **Virtus** shredders are equipped with a large diameter flat rotor. The knives are fixed in special knife holders fitted in machined pockets. Optional weld on hard facing is available for abrasive applications.

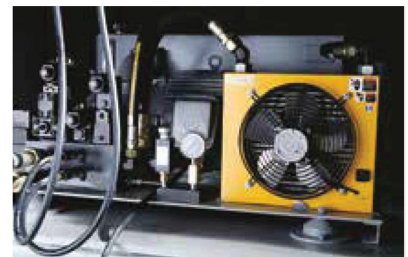

The X series shredders feature a high powered twin speed hydraulic system. This system ensures maximum pressure when feeding material into the rotor and high speeds on the backstroke.

Applications

The X series shredders have been designed for the most demanding and high throughput applications in recycling industries. The input materials can be all types of plastics, wood, paper, cardboard, e-waste, post-consumer waste, rubber, etc. in various shapes and sizes. Typical input materials are: fridges, purges, tires, pallets, bales, drums and barrels, pipes, film etc... The output material size is determined by the installed screen size and, except in some RDF (refuse derived fuels) and wood applications, the output material may need to be processed further to achieve the desired final size. For the recycling of complete truck and tractor tires the X-T model is configured with special wear protection and knives.

General Description

The X series shredders are single shaft shredders with a powerful two speed swing ram design eliminating the risk of blocking and wearing out of internal guide rails. The machine is very versatile and can be used for shredding of all kinds of input materials and is well suited for different industries. The 750 mm diameter rotors ranging from 1600 to 2800 mm width are driven by two oversized gearboxes. The low speed of 45 rpm guarantees a high torque and smooth operation.

The hydraulic power pack is well integrated into the machine housing to save space and protect it from damage but still easy to access or remove for maintenance. The proven E rotor, knife holder and knife designs are taken to new dimensions to conquer the most demanding applications and challenges. The machines can be tailored to various applications with advanced controls and hydraulics, hard facing and other wear options.

Virtus
Equipment

The Right Machine for Today's
Recycling Requirements

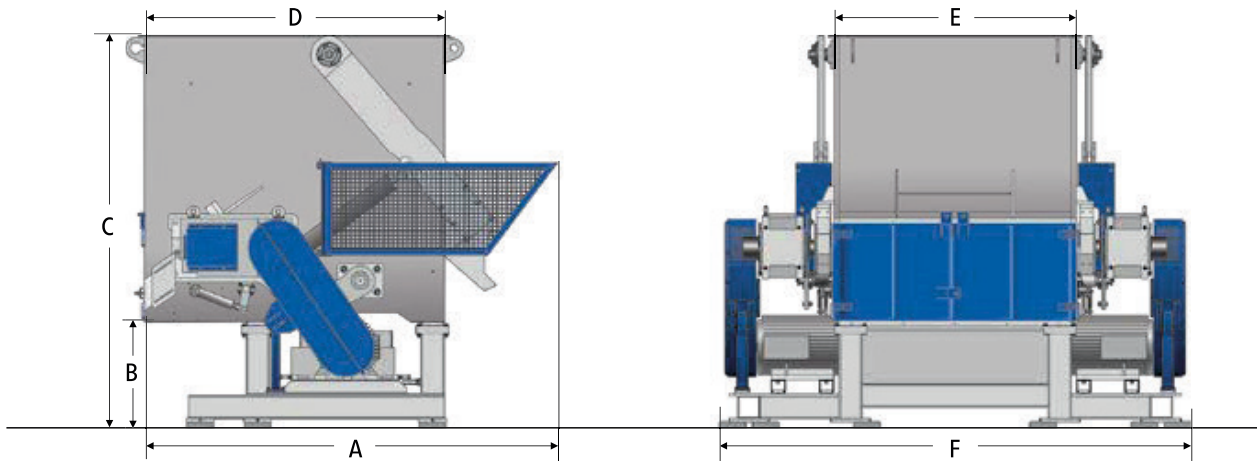

Technical Specifications

| Type | 1500 | 2000 | 3000 |
|--|-------------|-------------|-------------|
| Rotor diameter (mm) | 750 | 750 | 750 |
| Rotor width (mm) | 1500 | 2000 | 3000 |
| Rotor speed (rpm) | 46 | 46 | 46 |
| Drive capacity (kW) | 2 x 75 | 2 x 90 | 2 x 132 |
| Rotor knives (pcs) | 76 | 96 | 136 |
| Stator blades (rows) | 1 | 1 | 1 |
| Ram feeder drive (kW) | 11 | 11 | 11 |
| Screen size (mm) | > 60 | > 60 | > 60 |
| Cutting chamber volume (m ³) | 7.75 | 9.67 | 13.5 |
| Effective working area (mm) | 1500 x 1440 | 1500 x 1840 | 1500 x 2640 |
| Weight approx. (kg) | 17500 | 20000 | 25000 |

Dimensions

| Type | 1500 | 2000 | 3000 |
|--------|------|------|------|
| A (mm) | 3580 | 3580 | 3580 |
| B (mm) | 935 | 935 | 1015 |
| C (mm) | 3420 | 3420 | 3670 |
| D (mm) | 2540 | 2540 | 2540 |
| E (mm) | 1620 | 2020 | 2820 |
| F (mm) | 3560 | 4100 | 5070 |

Virtus Equipment

9120 Centerlinks Commerce Dr., Unit 4
Fort Myers, FL 33912

239-219-1800
Sales@Virtus-Equipment.com

virtus-equipment.com

Virtus
Equipment
The Right Machine for Today's
Recycling Requirements